

An Overview of Advanced Process Solutions

János Abonyi, Tibor Chován,
Lajos Nagy, Sándor Németh, Ferenc Szeifert

University of Pannonia
Department of Process Engineering

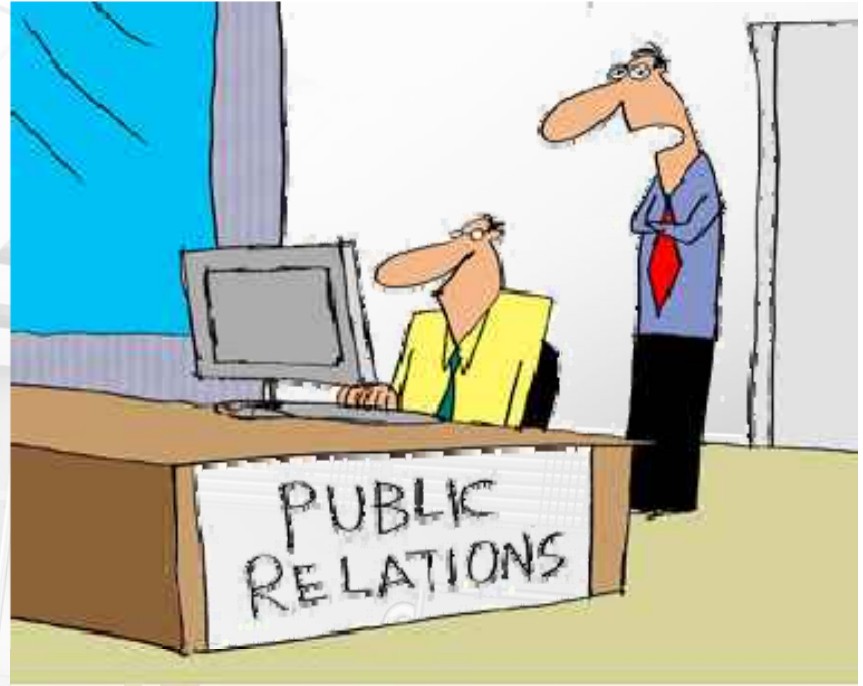

"Engineering has an idea for a new product. Send a new product release to the publications. If people show interest, we'll build it."

Advanced

at or close to the state of the art, enhanced; something that has moved forward in time or space in a late stage of development; greatly developed beyond an initial stage

10 Steps of Process Development at *Dow Chemical*

3/30

1. Produce a product without blowing the plant up. (at the beginnings)
2. Produce a product effectively and efficiently. (70's)
3. Produce a product optimizing multiple variables. (80's-?)
run the plant with less maintenance, higher yield, less energy,
quality at least as good or better than was produced before
(trial and error approach)

6. Optimization of the plant with continuous technical supervision

Control will be based not only upon the expertise of the operators, but upon the knowledge of all the people who have worked on the development of the chemistry and the process design.

Use the model (process simulator) to test out operating scenarios - higher rates, different feedstocks, modified operating conditions – before they are tried on the actual plant.

The model could also be used for operator training and to test start-ups and shutdowns.

Moreover, the model would run in real time, parallel to the plant, for model-predictive control.

Advanced?

4/30

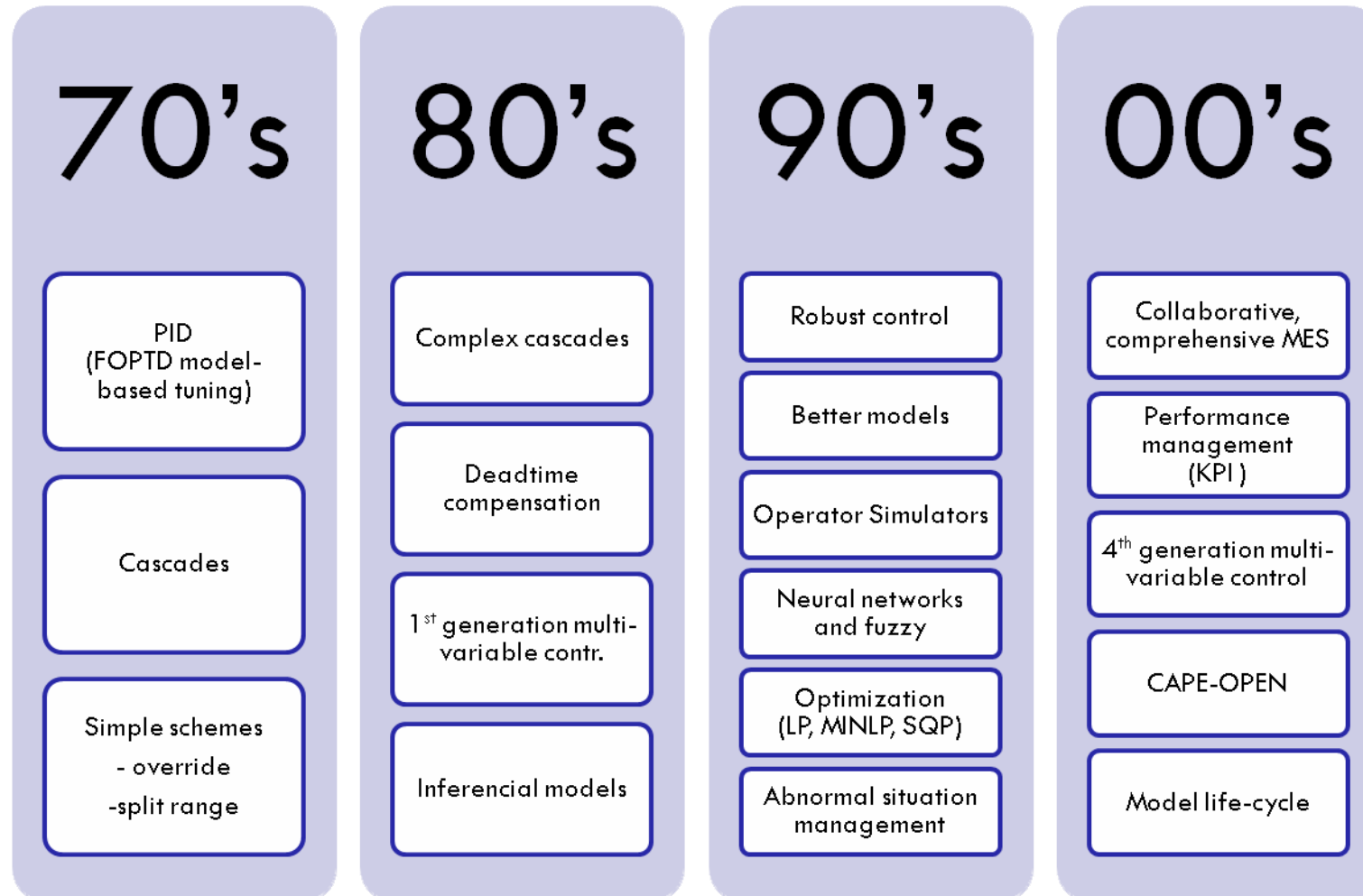

a 2% to 6% increase in production

a 2% to 3% increase in production

Industrial use of APC methods

5/30

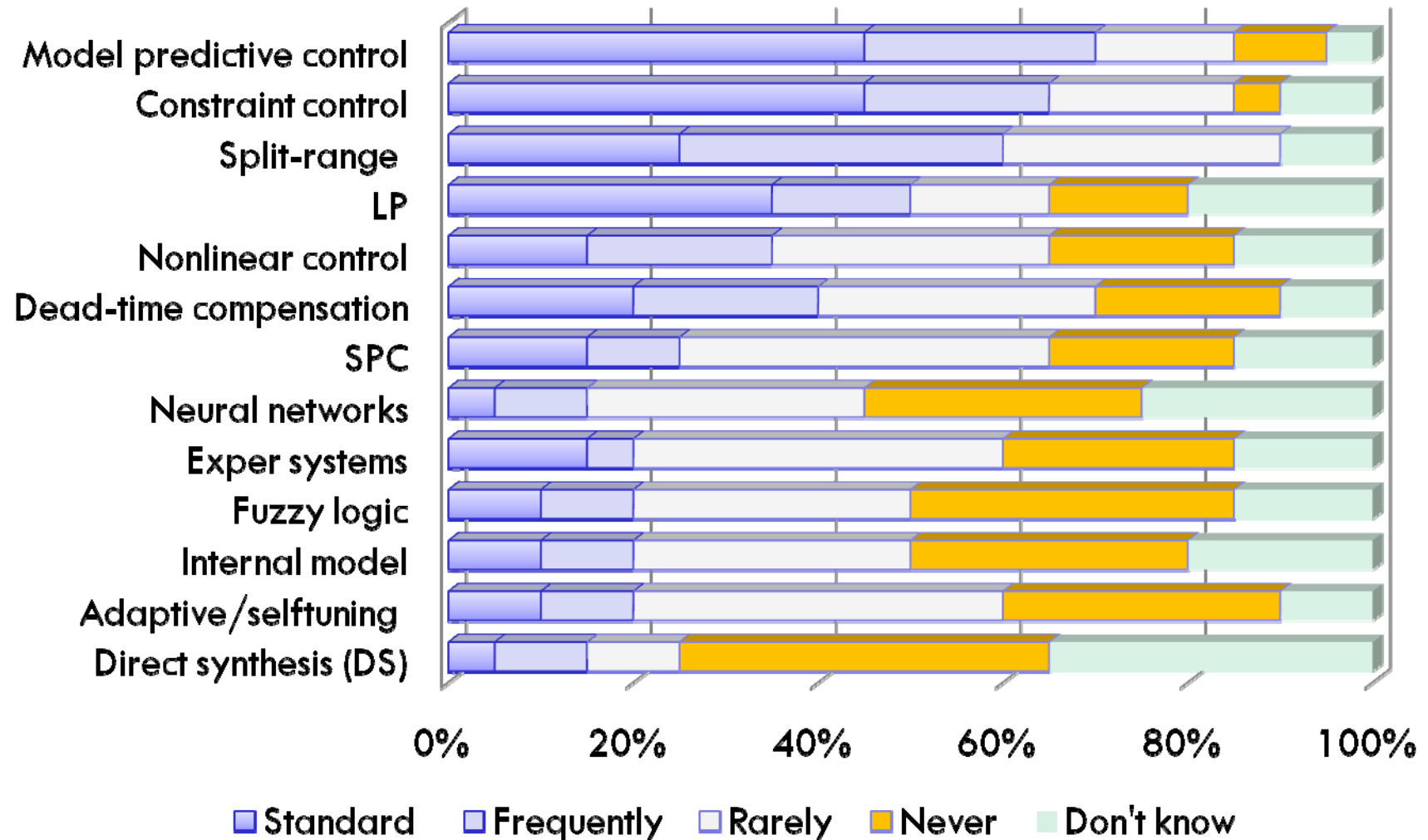

APC in the ISA-95 model

6/30

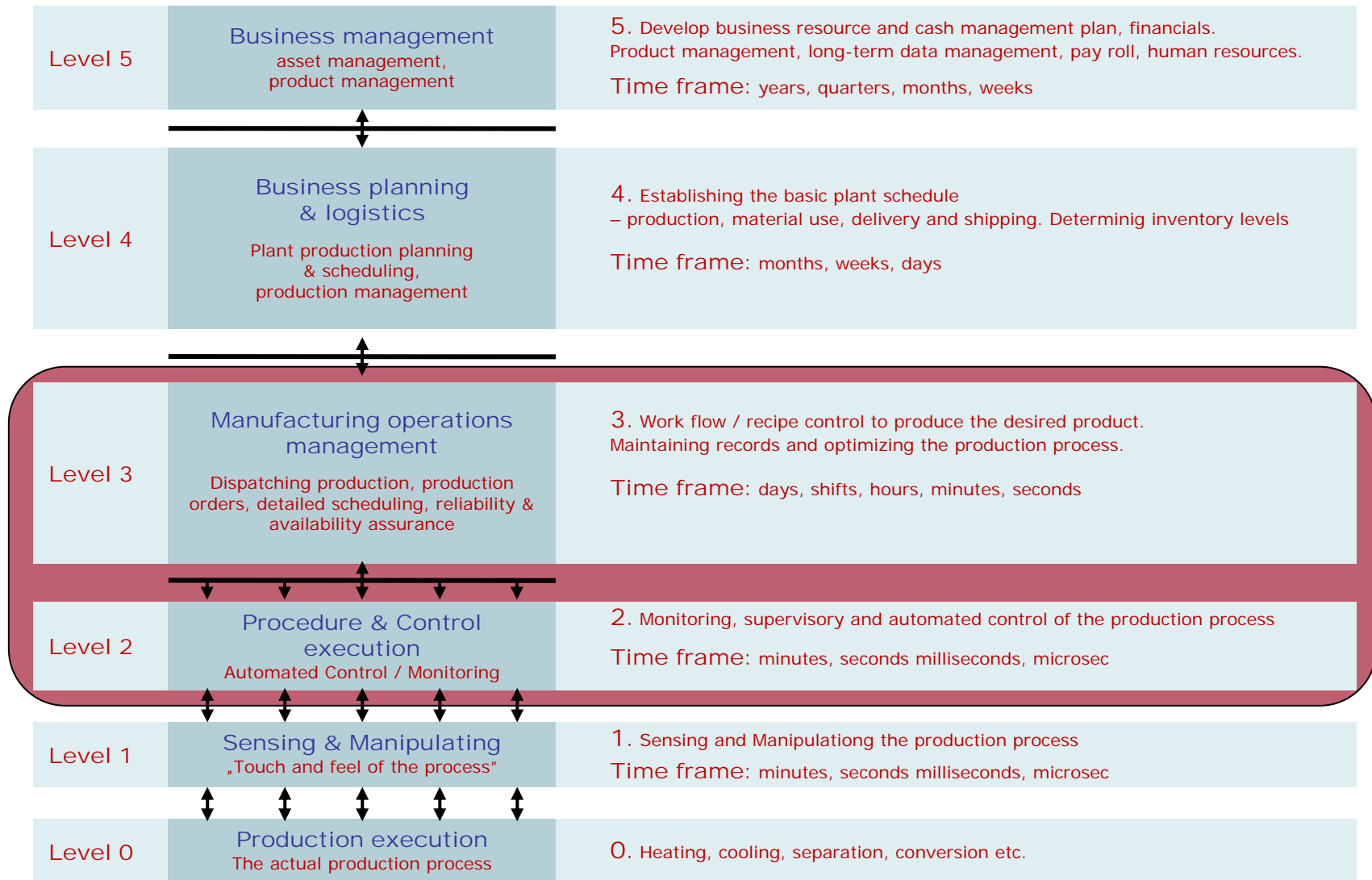

Expected costs v/s benefits

7/30

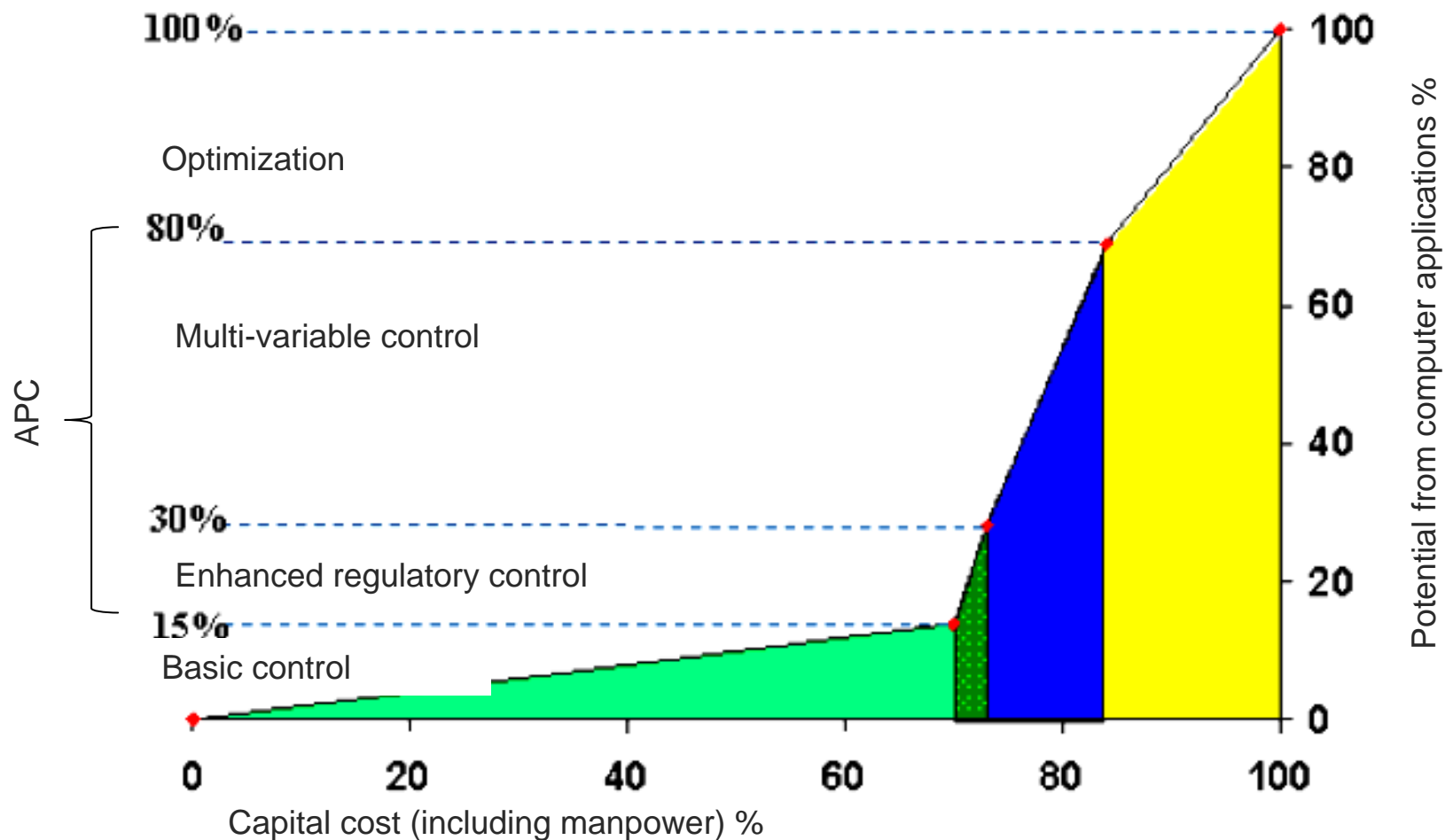

Source: Yokogawa APC white paper, 2001

“No amount of advanced control which relies on the use of poor field instrumentation can be expected to yield worthwhile benefit.

Thinking of control as a hierarchy, everything must work well at the lower levels for the higher levels above to work”.

M. J. Oglesby
ICI Engineering Technology

4th generation MPC

- RMPCT (Honeywell) and DMC-plus (Aspen)
- Multiple optimization levels to address prioritized
- Steady-state target optimization (QP)
- Robust control
- Advanced identification (PE, sub-space)

3rd generation MPC

- Several level of constraints (hard, soft, ranked)
- Recover from infeasible solution
- Change in the structure

2nd generation MPC

- QDMC
(quadratic programming to handle input-output constraints)
- What to do with infeasible solutions?

1st generation MPC

- IDCOM (1976)
- DMC – Shell Oil (no constraints, simple optimization)

Main profit contributors (%)

10/30

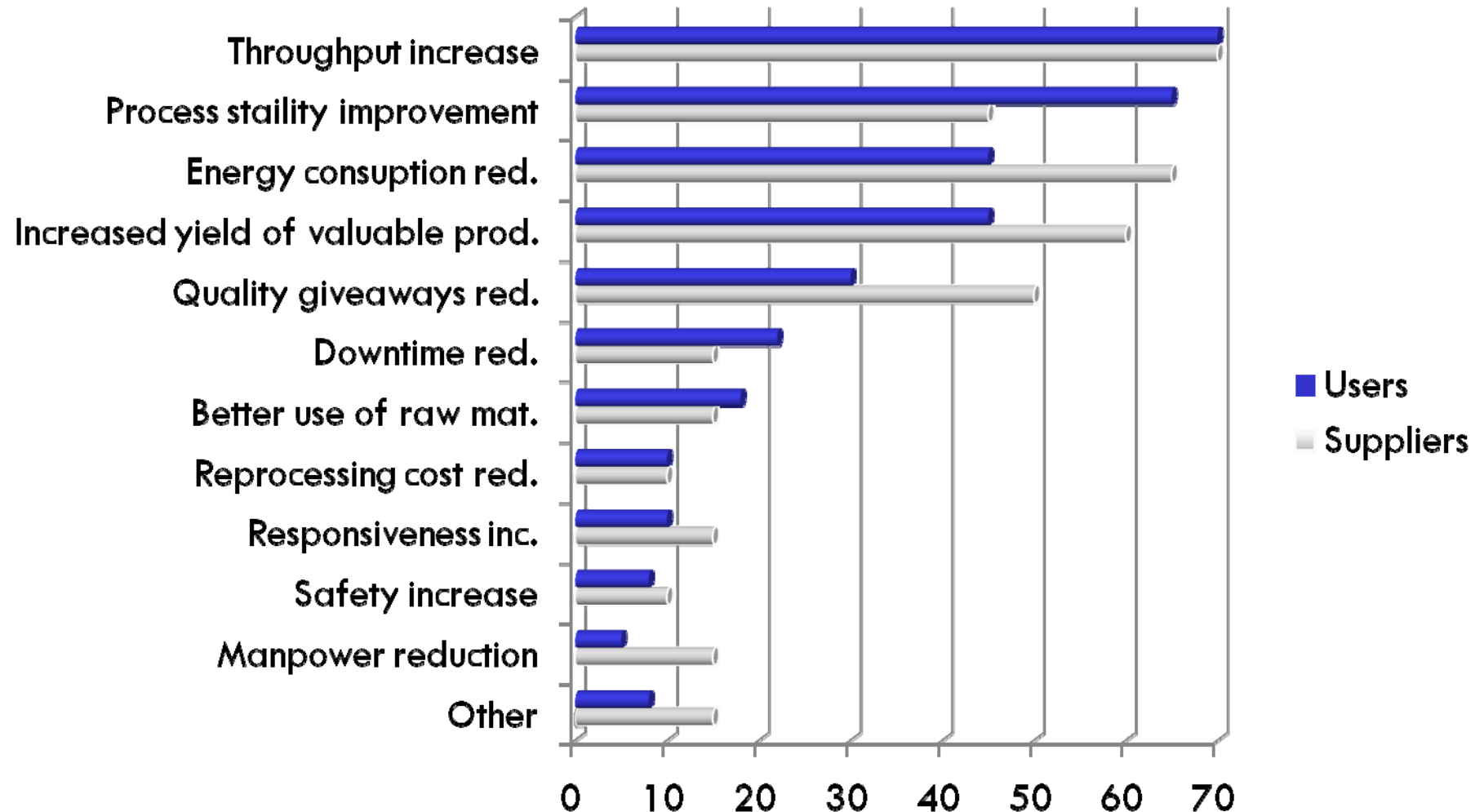

*„Anyone can reach a given setpoint or value by controlling the parameters in a technology, but to keep it **continuously** near those setpoints while production goes **in a reproducible way**, that is a challenge.”*

A. Kiss, senior plant engineer, TVK Plc. (2007?)

The reason and an idea ...

12/30

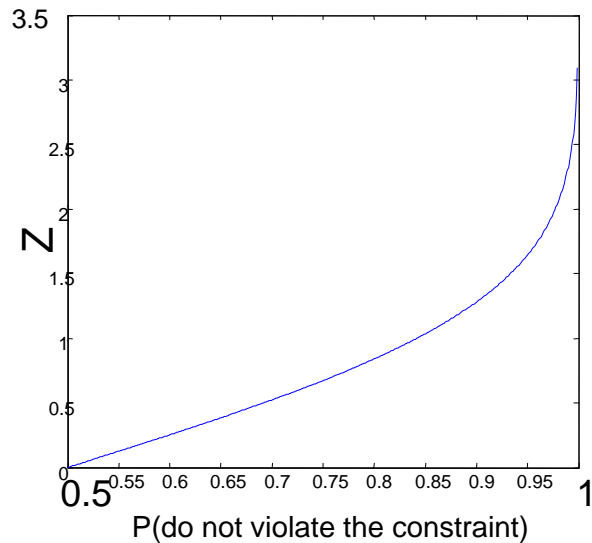
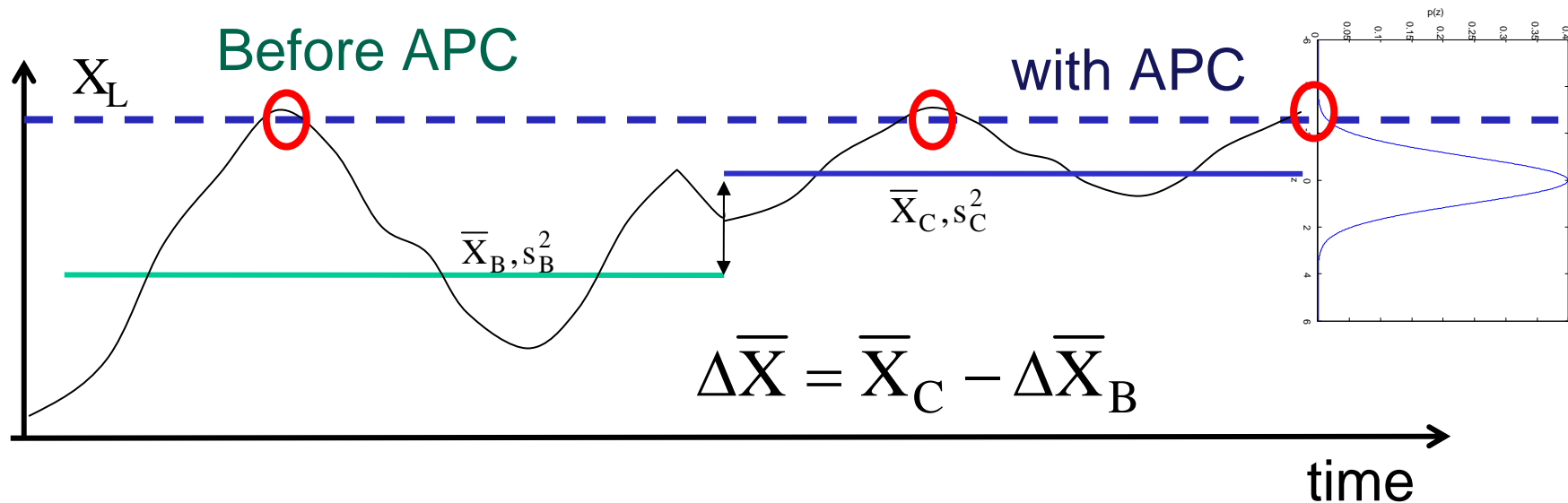

$$\bar{X}_C = \bar{X}_L - \sigma_C Z = \bar{X}_L - (\sigma_B - \Delta\sigma_P) Z$$

$$\Delta \bar{X} = \Delta\sigma_P Z$$

$$Z = f(\text{benefit} - \text{cost of constraint violation})$$

Questions ...

13/30

- How to calculate the variances?
- How to decrease the variances?
 - Better model - better controller?
 - » What is a good model? What to model?
 - » What kind of algorithm is „good“ for a model?
 - » What are the optimal controller settings?
- Where are the constraints?
- Are we sure that the constraints are „there“?
- What is the desired probability (and cost) of constraint violation?
- Is the economic optimum at the constraints?

I am sure you also have several ...

Information requirement - integrated usage of historical process data and models

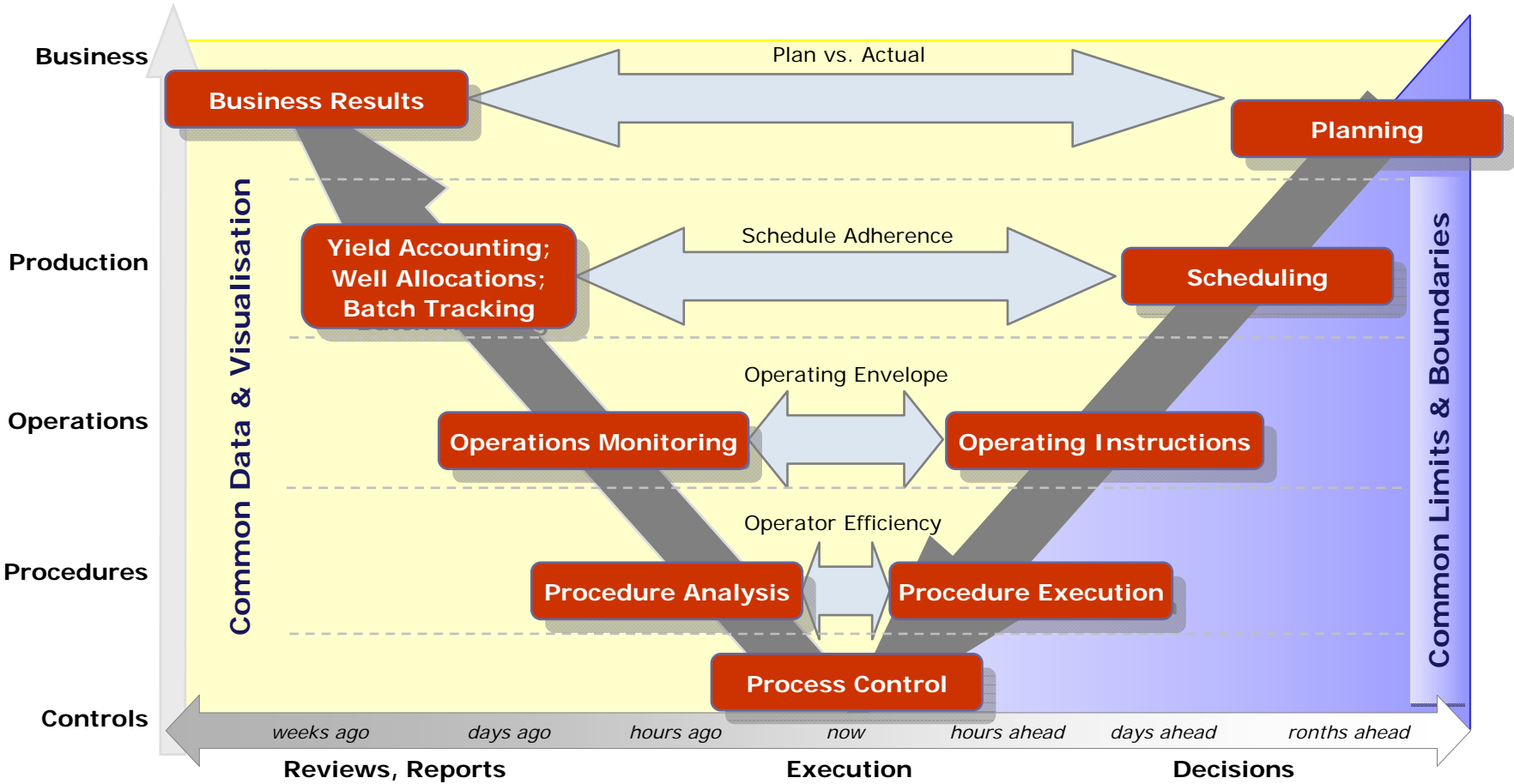

APC „workflow”

15/30

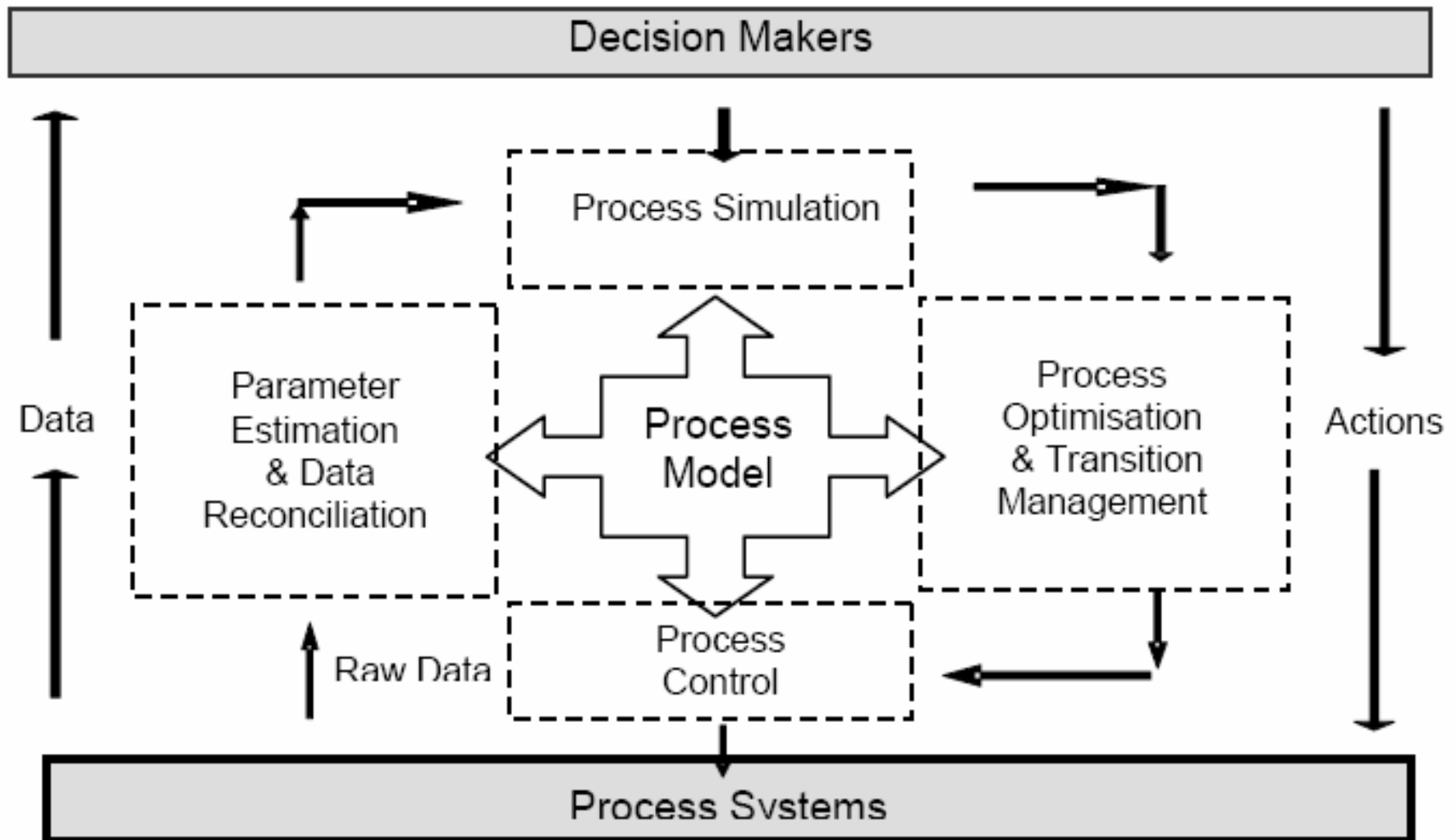

A key component in fulfilling all of Dow's goals is **to the reuse of engineering data across the plant life cycle.**

This involves creating an integrated, data-centric environment that enables the exchange of engineering information throughout the life cycle.

16/30

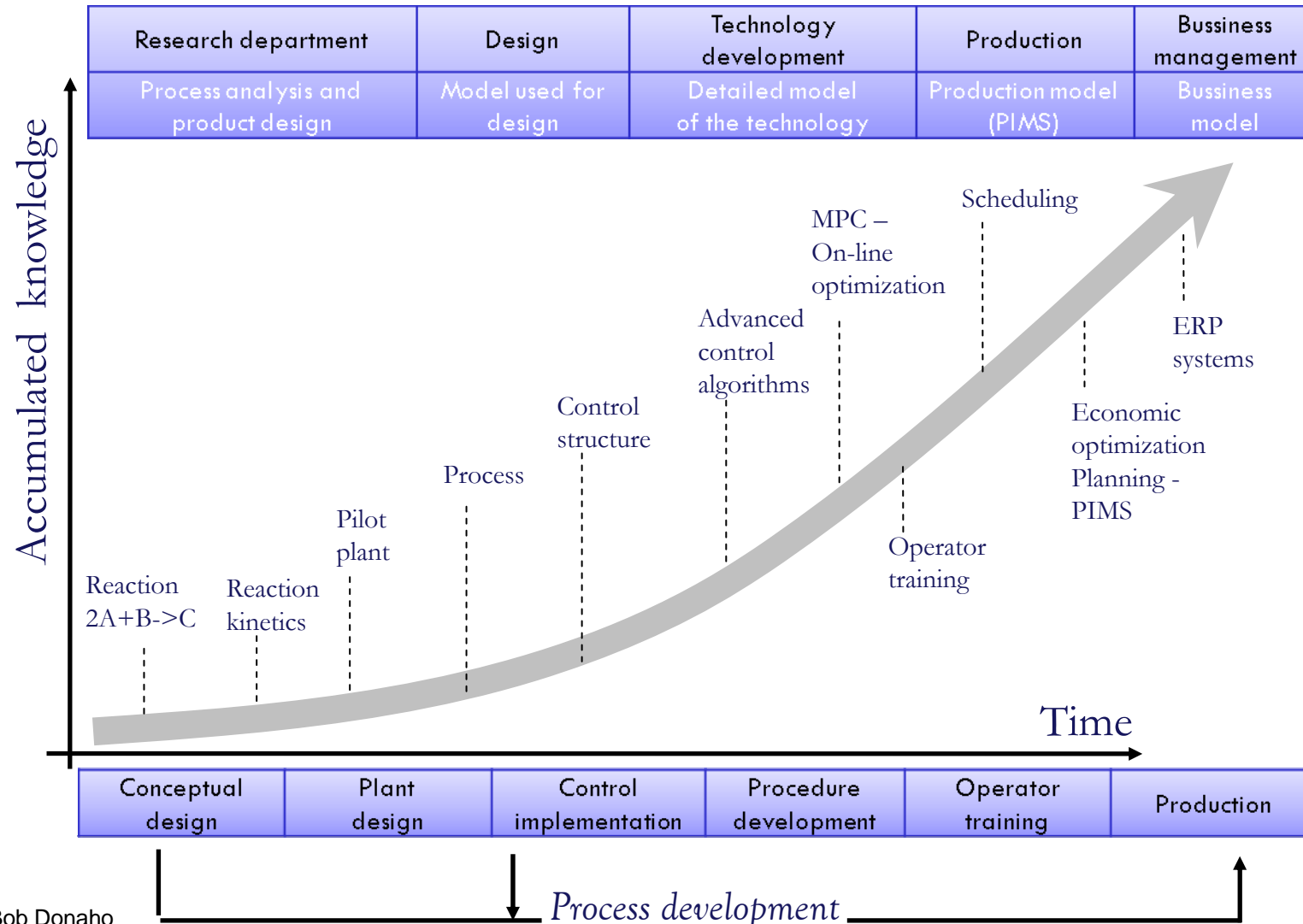

Source: Bob Donaho

Summary – Motivation

17/30

Proven to be profitable and reliable.

However, process models typically are developed uniquely without making use of already available process models.

Many achievements of academic research do not yet reach the industrial end-user, sometimes due to necessary refinements of the methods, but mostly due to the lack of affordable software implementations that are in line with the already company wide applied tools.

The economic break-even point is still relatively high, tailor-made approaches for smaller processes (e.g. batch/multipurpose units) are urgently needed to promote the technology more widely.

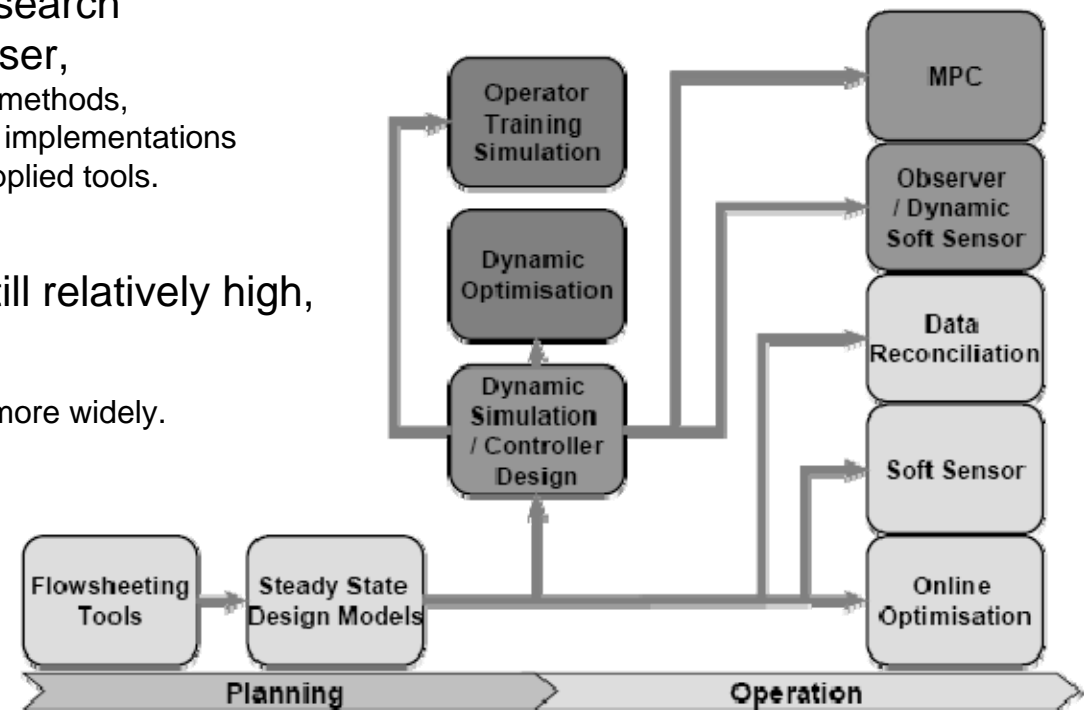

Delta V and BatchSim (OTS)

Delta V:

- Recipe management
- Control
- HMI,
- *I/O to BatchSim (OTS) by OPC*

BatchSim (OTS):

- Process structure, parameters,
- Reactions,
- HMI for parametrization,
- I/O to Delta V

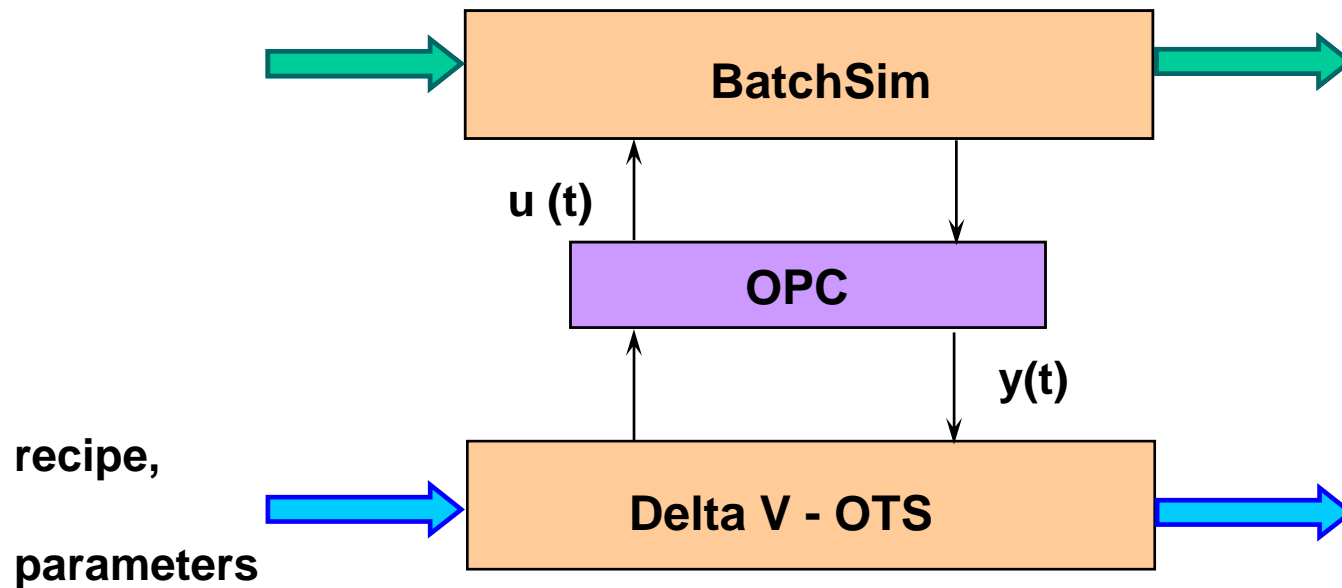

Case study ...



19/30

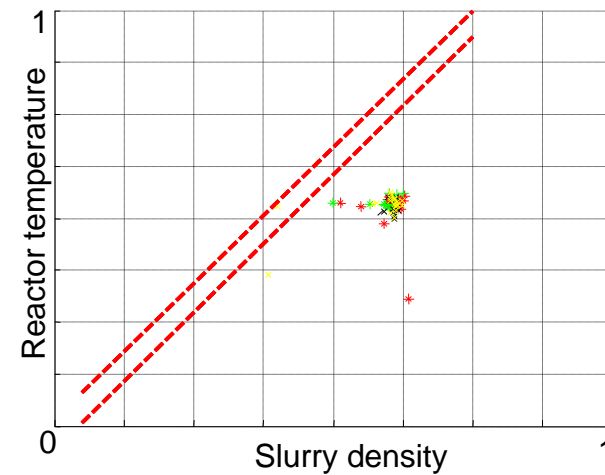
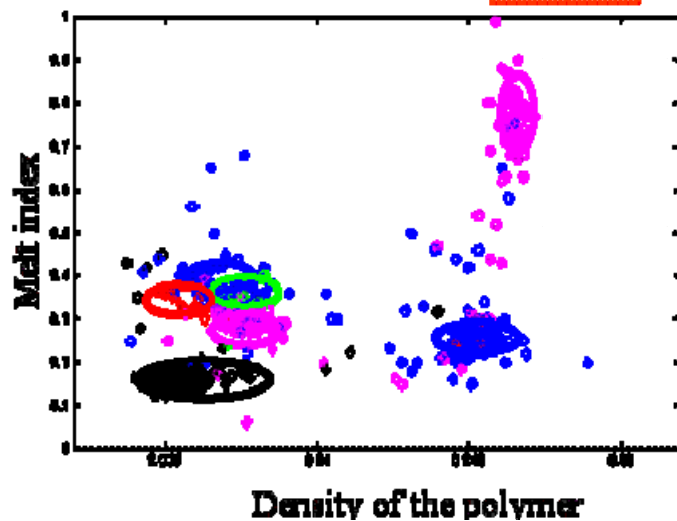
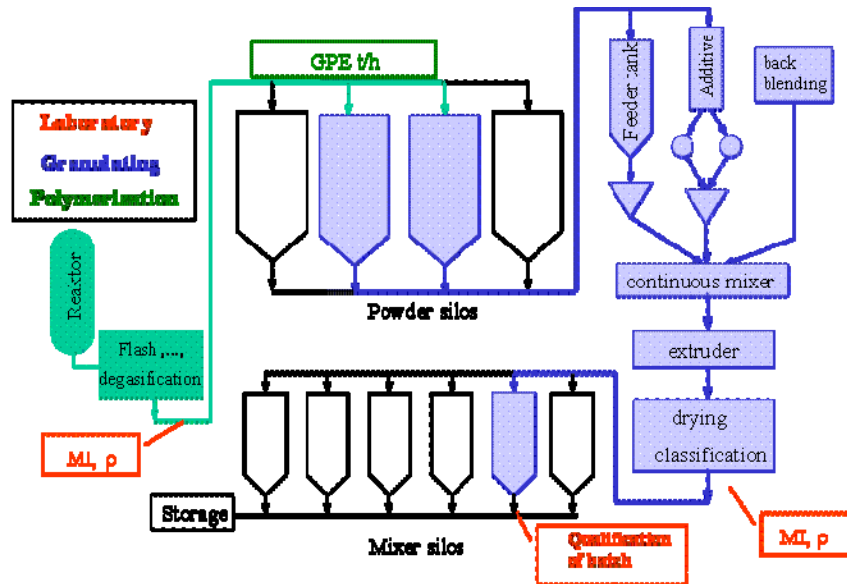

Control of multi-product processes
Huge capacity

Goal: Optimization of technology

Data warehouse is a subject-oriented, integrated collection of historical process data, which can provide appropriate basis for tracing the product and monitoring the production.

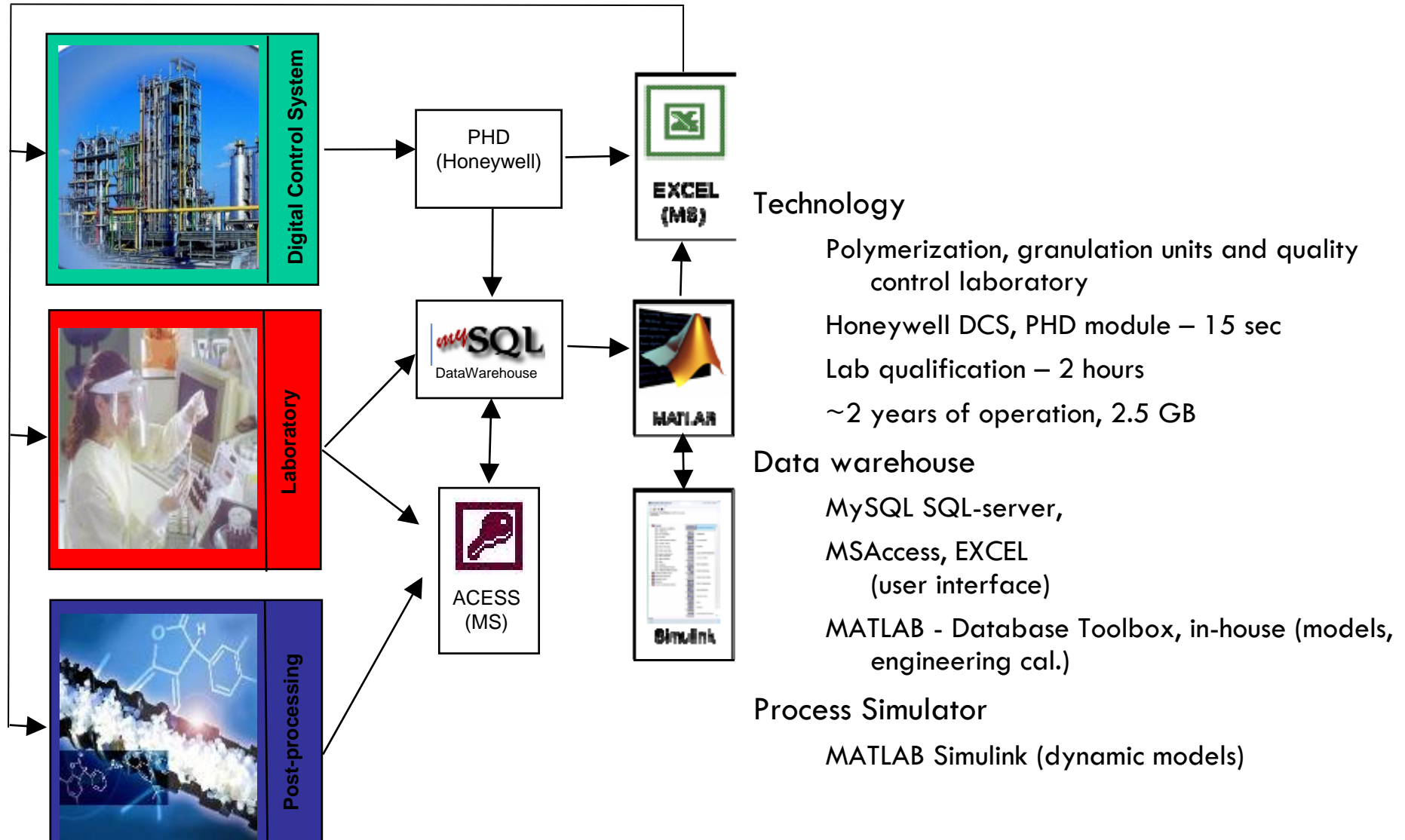

Process Monitoring based on Multivariate Statistical Analysis

21/30

Problem:

How to simultaneously monitor 10 - 100 process variables?

Solution:

Reduce the dimensionality of the correlated process data by projecting them down onto a lower dimensional latent variable space

Tools:

Principal Component Analysis (**PCA**) and/or Self-organizing Maps (**SOM**).

Beside process performance monitoring, these tools can be used for system identification, estimate the product quality for product design or soft-sensor building and for the determination of the „optimal” operating regimes.

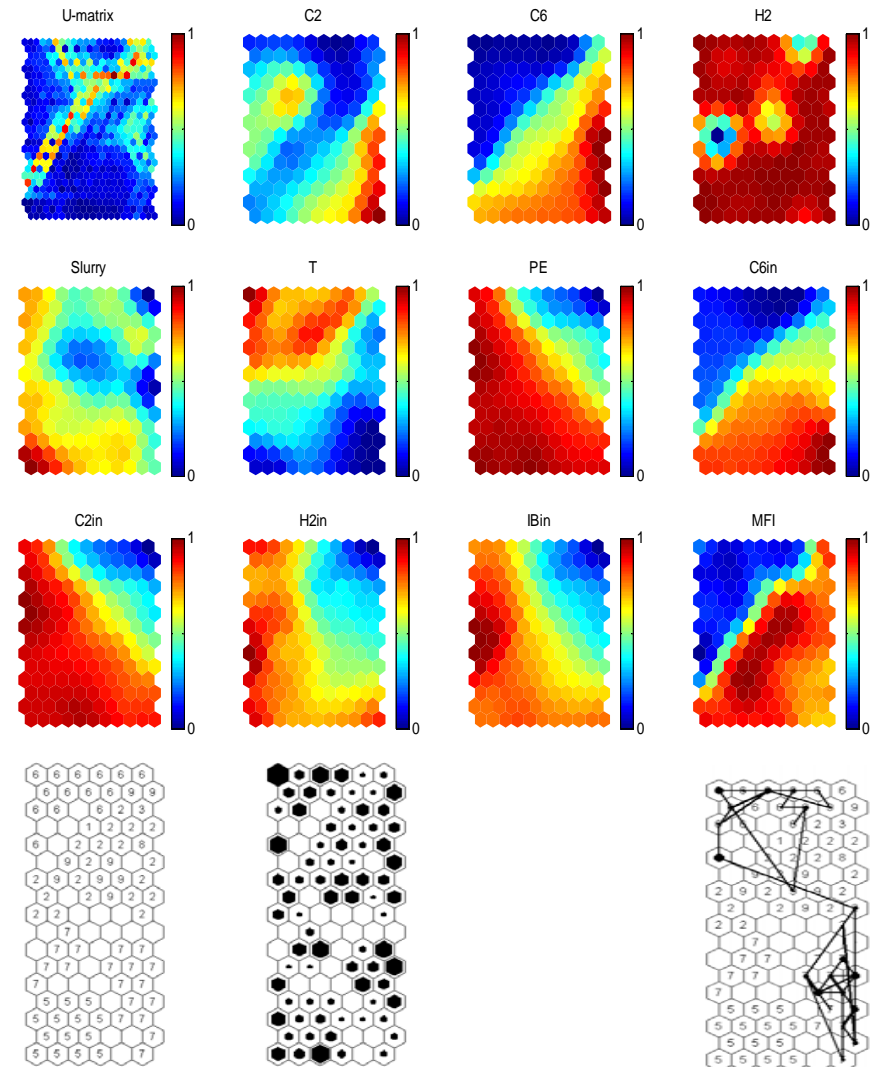

A black and white photograph showing a hand holding a magnifying glass over a document. The magnifying glass is positioned over a specific area of the document, suggesting a focus on detail or investigation. The background is dark and out of focus.

In data analysis
anomaly is more
interesting!

In-house (data-centric) APC

23/30

PLANT (PROCESS)

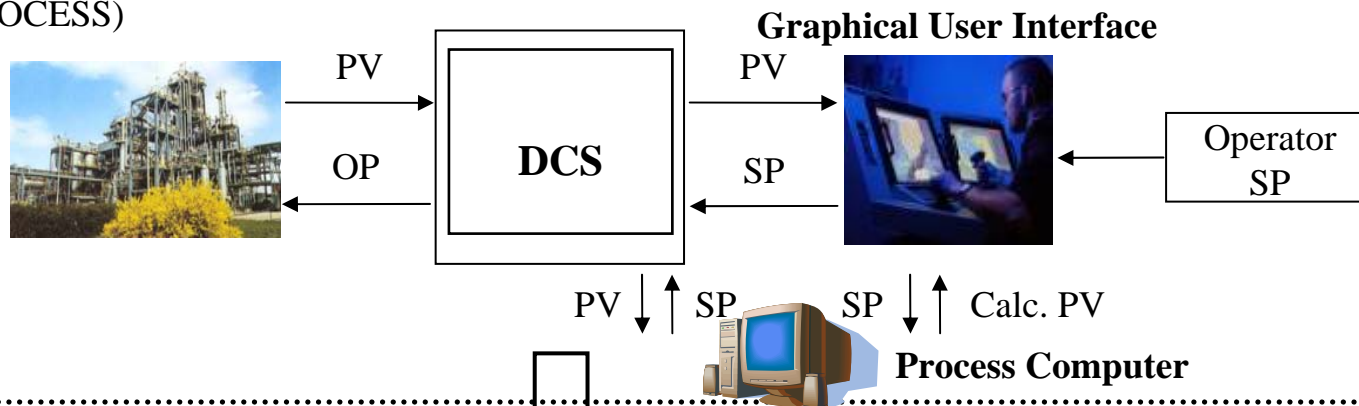

ANALYSIS LEVEL

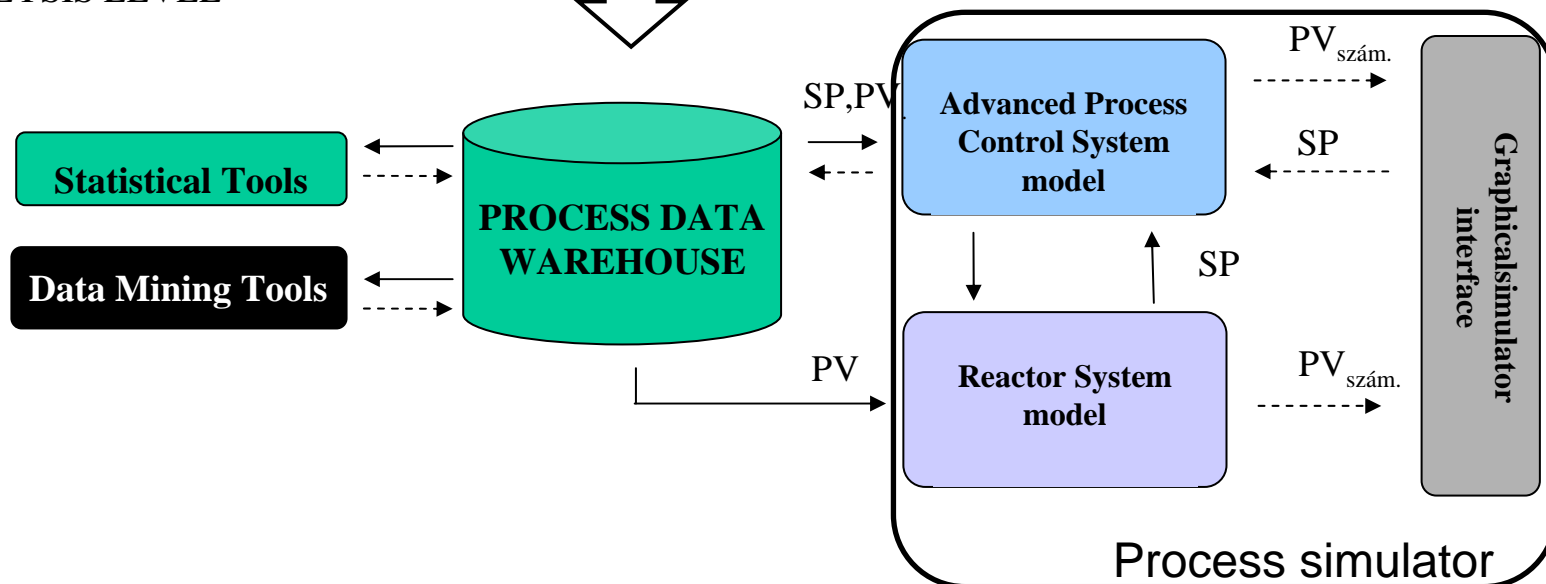

Implemented APC

24/30

- Reactants
- Production rate
- Heat transfer coeff.
- Output streams
- Outlet concentrations
- Productivity

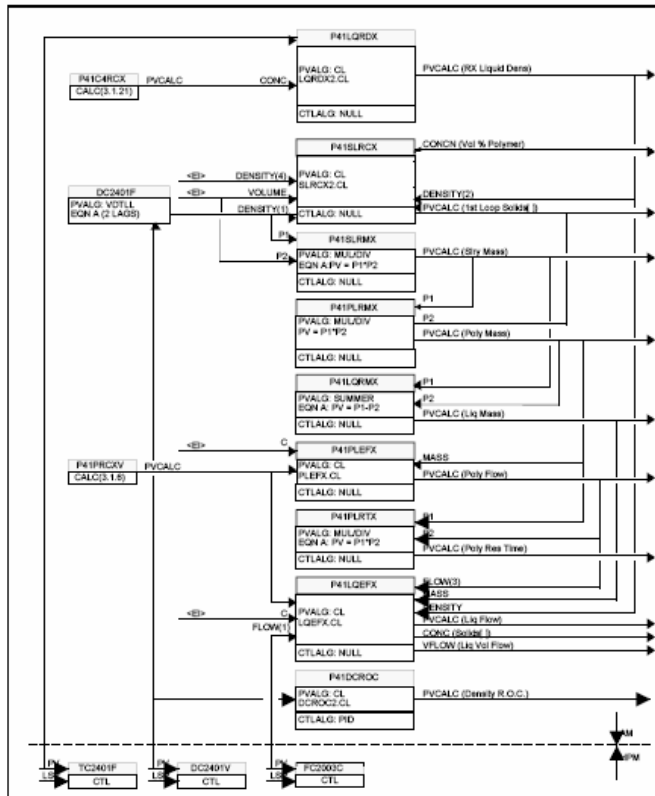

Advanced Process Control blocks (Honeywell)

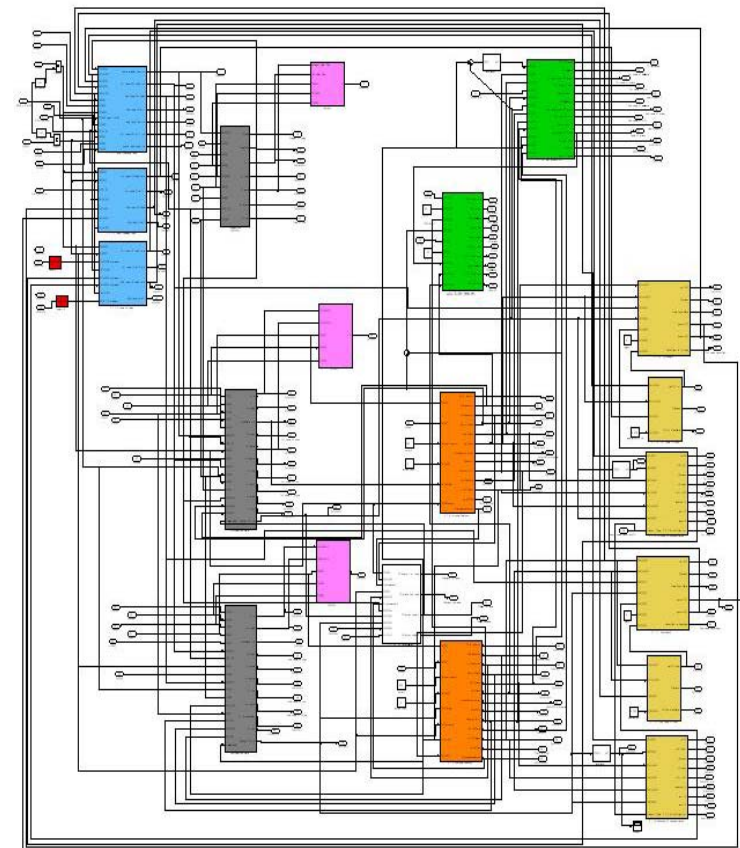

MATLAB/Simulink model of the APC

Product Quality Estimation

25/30

Semi-mechanistic models:

Neural networks or SOM models describe the unknown phenomena of the system that cannot be formulated by prior knowledge based differential equations.

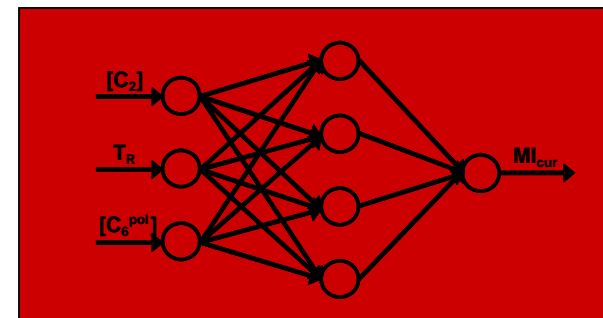
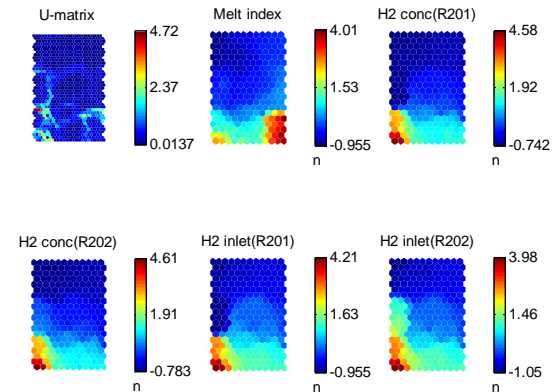
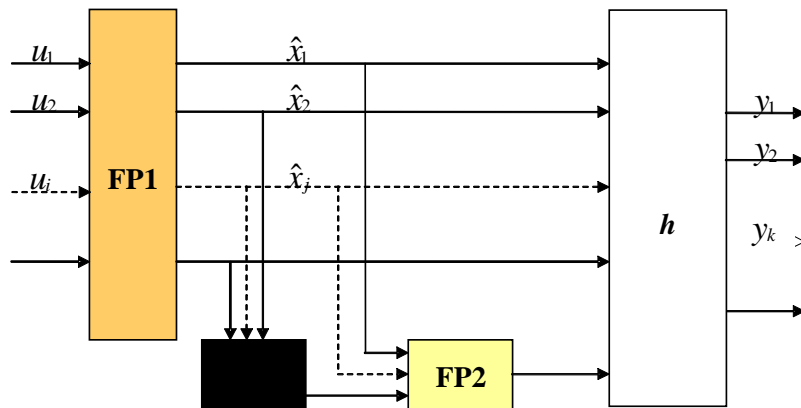

$$\frac{dMI_{cur}^{\xi}}{dt} = \frac{1}{P} \left(\sum_i k_i [i] L [cat]^p \cdot MI_{cur}^{\xi} - L_{out} MI_{cur}^{\xi} - MI_{cur}^{\xi} \frac{dP}{dt} \right)$$

just for demonstration ...

26/30

Time horizons, delays

First principle and semi-mechanistic models

Quality estimation

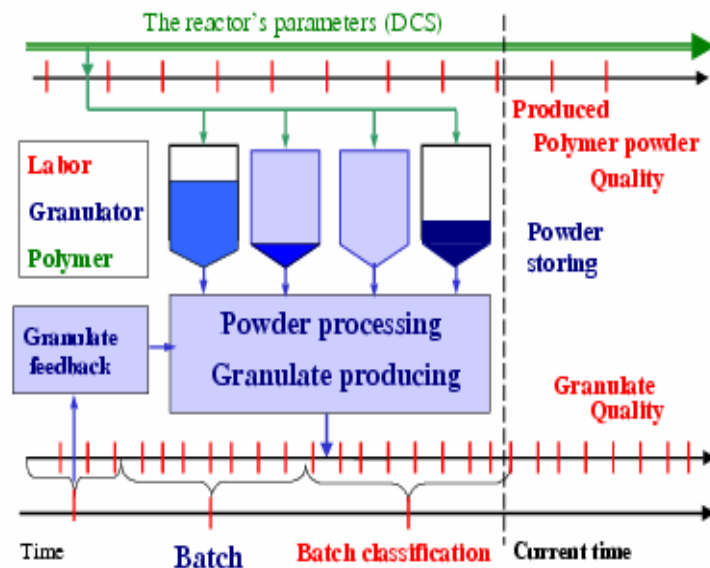

The model integrates the organization

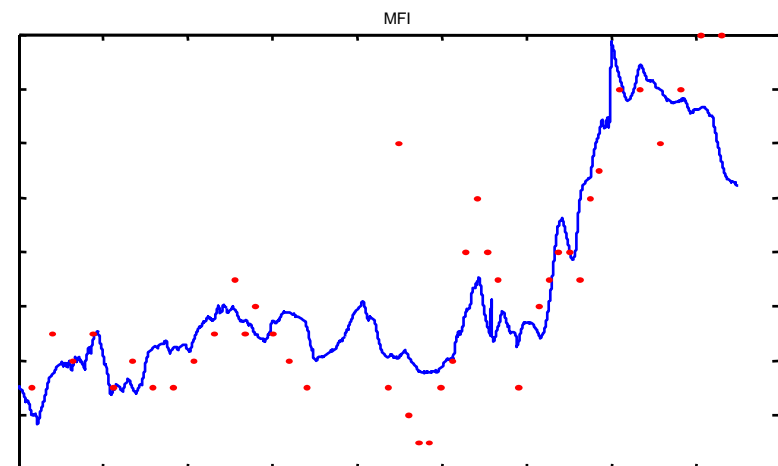
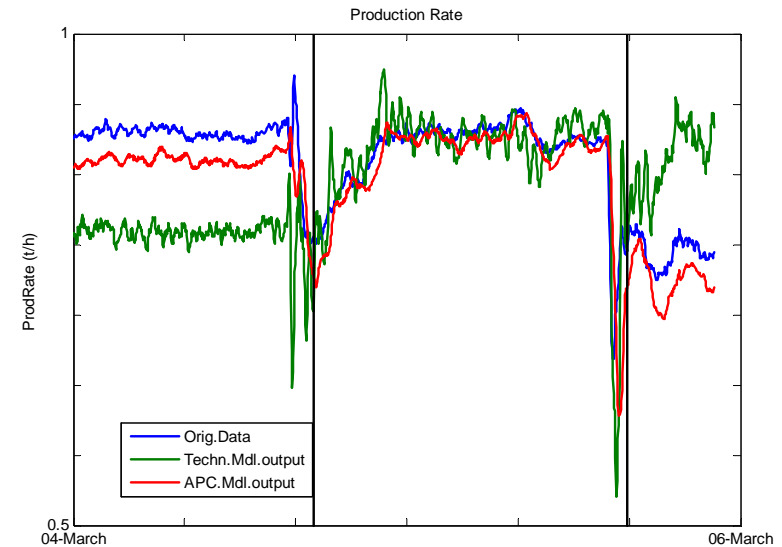

Future ... Experiment design ...

27/30

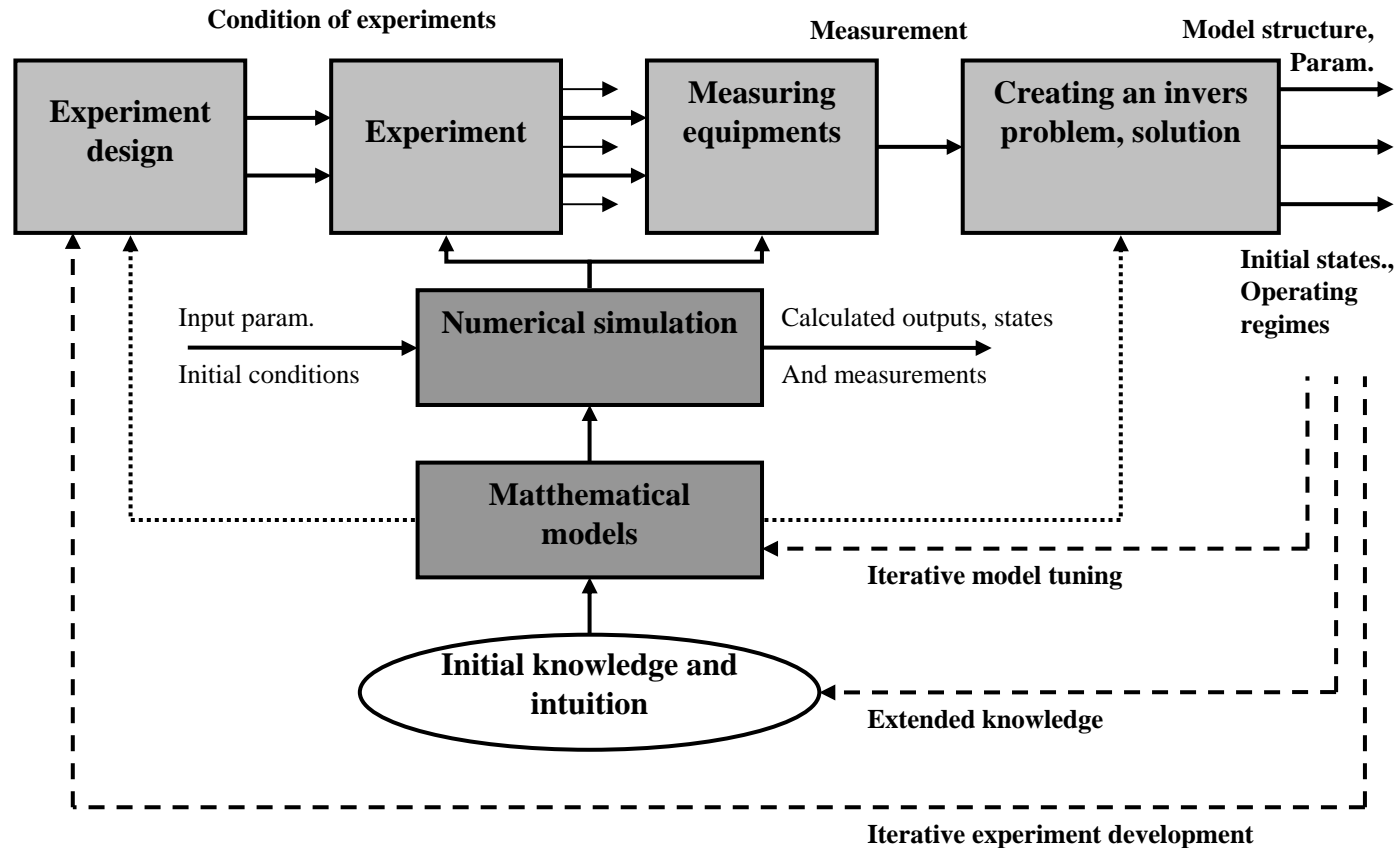

Experiments and design of experiment connect the modeling/simulation and measurements!!!

Source: Marquard, ESCAPE, 2008

Future

A good methodology should be based on the requirements of the
EN ISO 9001:2008 – Quality Management Systems European Standard

28/30

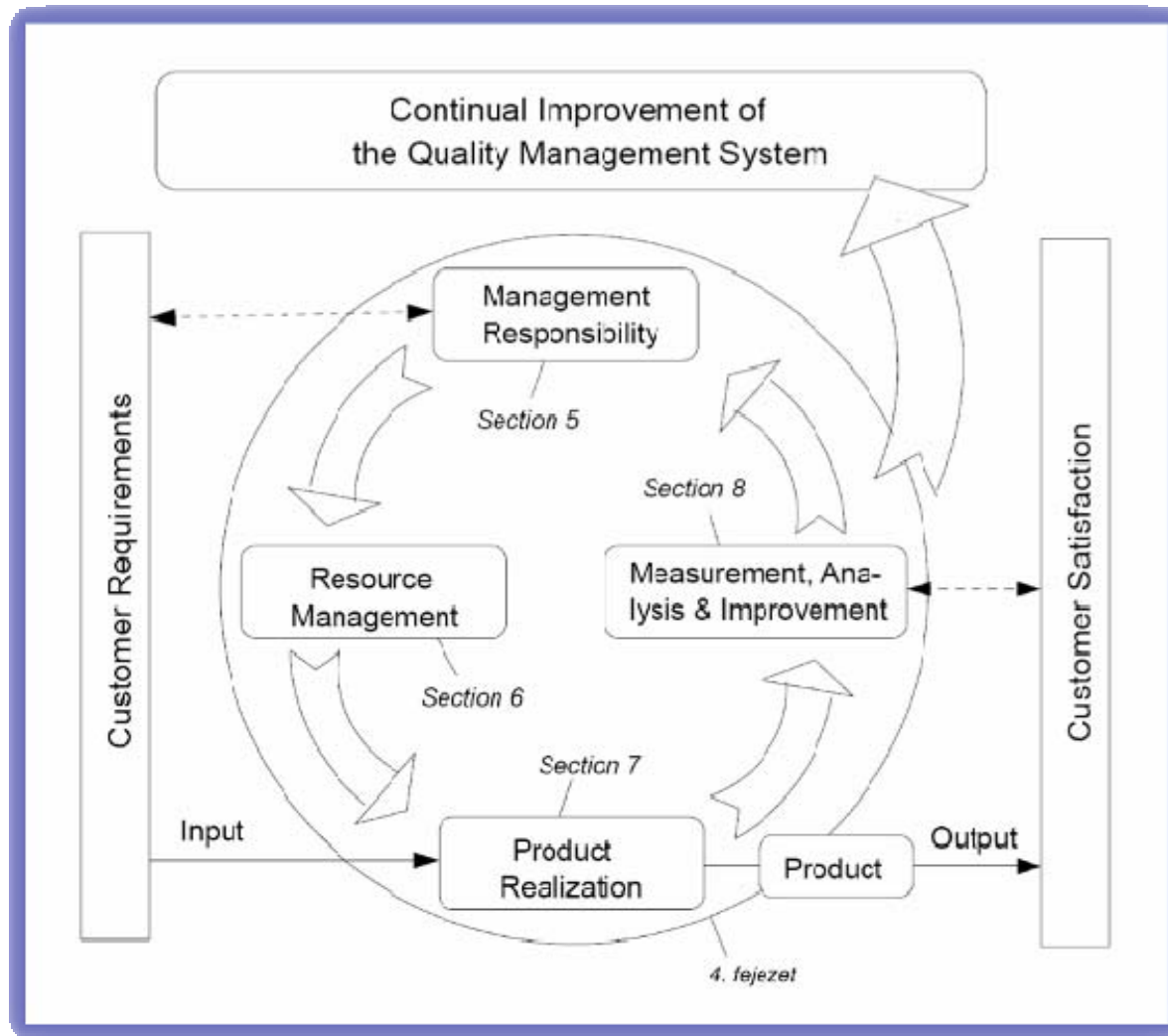

5.4.1 Set quality objects

...

7.5.3 Identification and traceability

7.6 Control of monitoring and measuring equipment

8.4 Analysis of data

Conclusions

29/50

- definitions of APC
- benefits of APC
 - showed a worldwide survey
 - What do you think about to make one in Central-Europe?
 - What do you think about to organize *the best APS of the year „competition”*?
 - proposed a technique for economic-oriented (probabilistic) APC tuning
 - it would be good to test it ...
- showed some results ...
how we do research with industry

... and that, in simple terms, this is my idea on APS.
... any questions?

